

M 250

M 250, the attention given to the study of shapes and the exclusive line design. The aesthetic and functional harmony in a great technological project.

A solid crane, equipped with advanced technologies, top quality materials and components, to obtain the best overall performance. Built for indoor and outdoor use in limited spaces and hardly accessible buildings.

The dimensions and lightweight, combined to millimetric precision manoeuvrability, allow quick and less invasive operations.

- Functionality:**
- Continuous boom rotation (as well with jib)
 - Boom free from ballast
 - Winch rope always ready, as well with Jib
 - Extension cylinders inside the jib
 - Jib always ready to use
 - various positions outriggers and high stroke to stabilize on every ground
 - Possibility to narrow the chassis up to 780mm
 - Double speed chassis
 - Simple to transport, as well with a light trailer, due to the reduced weight.

Power:

- 1250kg load capacity at 10,40 mt. height, with boom in vertical position
- 650 load capacity at 15,90 mt. height, with boom and jib in vertical position

Technologies:

Electric Engine Always Allowed.
3Kw Monophase Electric Engine, 220V Inverter controlled.

Electronic control system.
The integrated control system give to the crane the capabilities of automatically upgrading the load limiting device to the situation determined by the position of each outriggers; permitting the operator to completely work in safety conditions.

No Limits.
Easy to operate, around and over obstacles, thanks to the "ballast free" boom.

Over line Jib. +15° Jib to overtake beyond obstacles.

Jib Ready to Use.
Always "Ready to operate" folded hydraulic jib under the main boom.

BG LIFT, divisione "Gru compatte" di Brennero Gru, solida realtà produttiva nel settore del sollevamento. **BG LIFT** è un brand leader estremamente propositivo e fortemente focalizzato verso l'innovazione tecnologica e il design distintivo.

BG LIFT, A Brennero Gru "Compact Crane" Division, solid Production Reality of the Lifting Branch.
BG LIFT is a leader Brand, Extremely Positive, ambitious and deeply focused on technologic innovation and Peculiar Design.

BG LIFT, Abteilung für "kompakte Kräne" von Brennero Gru, solide Produktgesellschaft im Kran - Sektor.
BG LIFT, ist ein Leader-Brand und extrem Ausschau-haltend für Innovation in der Technologie und Design.



M 250

GRU CINGOLATA COMPATTA
COMPACT CRAWLER CRANE
KOMPAKTKRAN AUF ROLLSCHIENEN

Der M250 - der innovative Minikran der Design, Form und Funktion perfekt vereinbart! Als Grundlage für beste Performance dienen modernste Technologie und Komponenten in bester Qualität. Dank kompakter Dimensionen und geringem Gewicht sowie millimetergenauer Steuerung werden Arbeiten sowohl im Innen- als auch Außenbereich schnell und effizient erledigt.

- Bedienbarkeit:**
- Endlos drehen
 - Ballastfreier Arm
 - Immer bewaffnetes Schleppwinde Kabel, auch mit Jib installiert
 - Innenliegender Hauptzylinder
 - Kranspitze ausklappbar und somit immer hubbereit
 - flexible Abstützung für jedes Gelände
- Raupenfahrwerk verstellbar, min. 780 mm
 - 2 Fahrgeschwindigkeiten
 - einfach mit Hänger transportierbar dank geringem Eigengewicht

Leistung:

- 1250 kg Last zu einer Höhe von 10,40 m, mit vertikalem Arm
- 650 Kg Last zu einer Höhe von 15,90 m, mit vertikalem Arm und Jib

Technologien:

Elektroantrieb
3Kw Elektromotor mit 220V Frequenzumrichter.

Elektronisches Steuerungssystem Das integrierte Lastsystem berechnet auf Grund der Sensoren in der Abstützung automatisch die aktuell möglichen Traglasten und bietet so dem Bediener immer größtmögliche Sicherheit.

Keine Grenzen
Endlos Drehen ohne Ausscheren da das Gegengewicht nicht am Arm montiert ist.

Over Line Jib Jib bei + 15 °, um Hindernisse zu überwinden.

Jib einsatzbereit
Kranspitze ausklappbar, somit immer hubbereit

M 250



Ing. Leeb GmbH
Hebe- und Montagetechnik, Kूपfern 45, A-3335 Weyer
Telefon +43 (0)7355 8478-0, Fax +43 (0)7355 8478-20
www.leeb-technik.at, eMail: office@leeb-technik.at

Alle Angaben unterliegen der technischen Weiterentwicklung.
Die Geräte entsprechen den neuesten technischen Sicherheitsrichtlinien.
Mögliche konstruktive Änderungen vorbehalten.



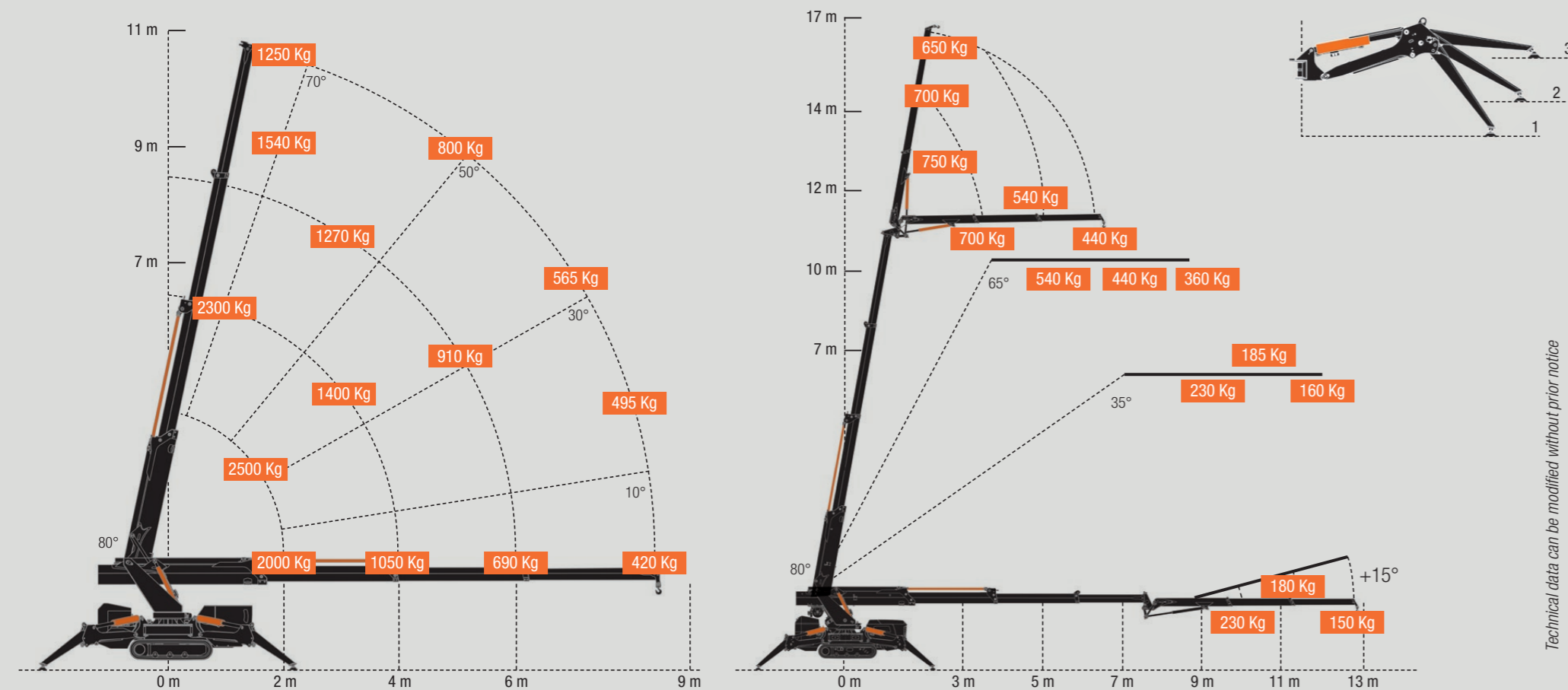
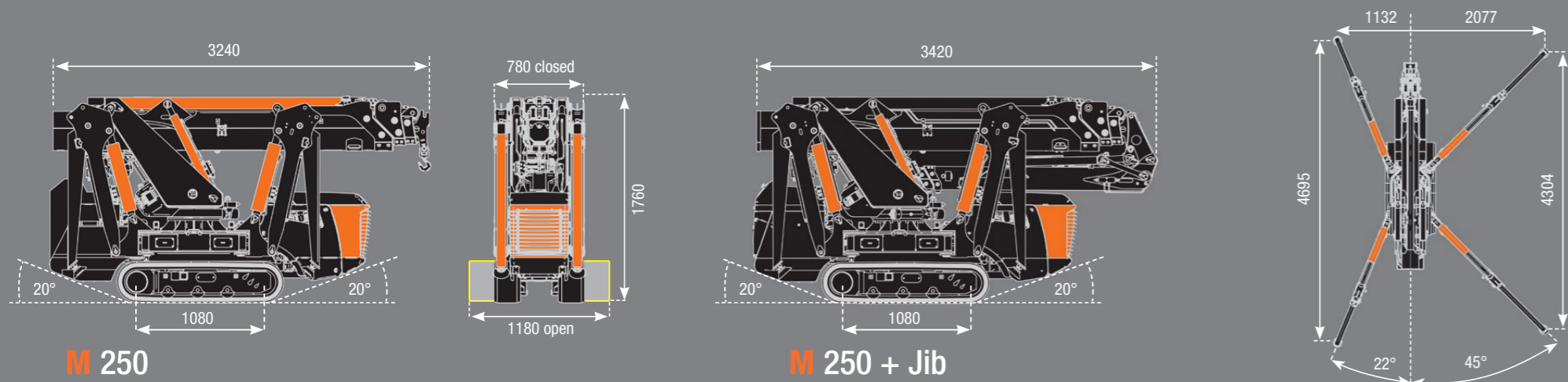

Technical data can be modified without prior notice



SPECIFICHE TECNICHE / TECHNICAL SPECIFICATIONS / TECHNISCHE MERKMALE

	Carico massimo gru Max capacity Traglast	2500 Kg / 1,5 m
	Raggio massimo di lavoro Max outreach Maximaler Arbeitsradius	8,43 m
	Raggio massimo di lavoro con Jib idraulico (optional) Max outreach with Jib (optional) Maximaler Arbeitsradius mit hydraulischem Jib (optional)	12,85 m
	Altezza massima del braccio Max hook height Maximale Höhe des Armes	10,40 m
	Altezza massima con Jib idraulico (optional) Max hook height with Jib (optional) Maximale Höhe des Armes mit hydraulischem Jib (optional)	15,90 m
	Angolo di rotazione-Velocità Slewing angle-speed Schwenkbereich - Fahrgeschwindigkeit	Continua / 1,5 rpm Continuous / 1,5 rpm Endlos / 1,5 rpm
	Argano (optional) Winch (optional) Seilwinde (optional)	Tiro in diretta / First layer pull / Traglast 1-strangig Lunghezza fune / Rope lenght / Seillänge Velocità in tiro diretto / Speed in direct pull / Geschwindigkeit bei 1-Strang-Betrieb
	Radiocomando Radio remote control Fernsteuerung	Sanreco Can-Bus + Dispalpy
	Limitatore di carico Stability control Lastmomentbegrenzer	Elettronico Electronic computergesteuert

	Stabilizzazione Stability system Abstützung	24 posizioni 24 different position 24 verschiedene Positionen	Max 4155x4300
	Peso degli elementi Weights Gewichte	Gru standard / Standard crane / Standard kran Jib Motore elettrico / Electric motor / Electromotor Argano / Winch / Seilwinde	2250 Kg 210 Kg 40 Kg 65 Kg
	Trazione carro cingolato Crawler Crane Traction Antrieb des Raupenkrans	Trasmissione / Transmission / Antrieb Portata / Scope / Zulässiger Durchfluss Pressione / Pressure / Druck Velocità / Speed / Fahrgeschwindigkeit Pendenza max / Max slope degree / Max. überwindbare Steigung Pressione al suolo / Max pressure on the ground / Bodendruck	Riduttore Epicicloidale / Moto-reducer / Planetengetriebe 50 l/min 170 bar 0 - 2 Km / h 25° 0,47 Kg / cm ²
	Motore diesel Diesel Engine Diesel Motor	Marca / Brand / Marke Modello / Model / Typ Potenza max / Max power / Max Leistung Coppia max / Max torque / Maximale Drehmoment Capacità serbatoio / Tank capacity / Tankinhalt	Yanmar 3TNV70 16.3 kw / 22.2 Hp 48 Nm 13 l

OPTIONAL

- Argano idraulico da 900 Kg
- Ganci Ribassati
- Carrucole per tiro triplo
- Cestelli porta operatore
- Fari di lavoro
- Jib idraulico con operatività di 195°
- Motore elettrico 220 V monofase con inverter
- Cingoli antitraçcia
- Piastre maggiorate per stabilizzatori
- Olio Idraulico biodegradabile.
- 900 Kg hydraulic winch
- Lowered Hook Connections
- Third line pull pulleys
- Plates for outriggers
- Working Lights
- Hydraulic Jib with opening Up To 195°
- Three Phases Electric Engine 2,2 Kw/220 V
- No marking rubber pads
- Two Man Capacity Baskets
- Green Oil
- Hydraulische Seilwinde Traglast max. 900 Kg
- Fixhaken mit Schwannenhals
- 3-fach gesicherte Hakenflasche für 2.500kg
- Arbeitskorb für Personen
- Arbeitsscheinwerfer
- Hydraulischer Jib mit 195° Knickradius, überstreckbar
- 220V Einphasen-Elektromotor mit Inverter
- Non-Marking Gummiketten
- Plattformen für Stabilisatoren
- Biologisch abbaubares Hydrauliköl

DOTAZIONI STANDARD / STANDARD EQUIPMENT

- Radiocomando con display per ogni funzione del carro, stabilizzatori e gru
- Rotazione continua
- Predisposizione per argano
- Predisposizione per il Jib
- Stabilizzazione a più posizioni
- Stabilizzazione Automatica
- Avanzamento cingolo a 2 velocità
- Acceleratore dei giri motore
- N° 4 attacchi per il sollevamento
- Limitatore di carico elettronico
- Autodiagnosi
- Gru colore nero RAL 9005
- Cilindri colore arancio
- Normativa di riferimento EN13000.
- Radio remote control with display for crawler, chassis and crane function.
- Continuous rotation
- Predisposition for winch Installation
- Predisposition for Jib Installation
- Outrigger with different stability position
- Automatic stabilization
- Two Speed Crawler Translation
- Engine Rpm increment
- N° 4 Lifting Connections
- Electronic Limiting Device
- Auto diagnostic
- Crane Color Black RAL 9005
- Cylinders color orange
- According To EN13000
- Fernbedienung mit Display für alle Funktionen des Rahmens (Fahrwerk), Stabilisatoren und Kran
- ungeschänkte Rotation
- Vorbereitung für Winde
- Vorbereitung für JIB
- Multi-Positions- Abstützung
- Automatische Abstützung
- zweistufige Geschwindigkeit der Gleiträder des Raupenfahrwerks
- Beschleuniger für Drehzahl
- 4 Anschlaghaken für das Heben von Lasten
- Elektronische Abregelung bei Überlastung
- Auto-Diagnose
- Farben des Krans Schwarz RAL 9005
- Farben der Zylindern Orange
- Übereinstimmung mit der Norm EN 13000.

M 250, lo studio delle forme e il design esclusivo delle linee. L'armonia estetico-funzionale di un grande progetto tecnologico. Gru compatta, equipaggiata con tecnologie innovative, componenti e materiali di qualità, per ottenere le migliori performance. Progettata sia per utilizzo interno, che esterno. Ideale per operare in accessi difficili e spazi limitati. Le dimensioni e il peso contenuti, unite ad una manovrabilità con precisione millimetrica, consentono lavori rapidi, veloci e meno invasivi.

- Operatività:**
- Rotazione continua del braccio (anche con Jib)
 - Braccio libero da zavorra
 - Fune del verricello sempre armata, anche con Jib installato
 - Cilindri di sfilo interni al Jib
 - Jib sempre pronto all'uso
 - Stabilizzatori con varie angolature e grande escursione per ogni terreno
 - Carro cingolato restringibile fino a 780 mm
 - Carro con doppia velocità
 - Trasportabile con carrello leggero grazie al peso ridotto.

- Potenza:**
- 1250 Kg di portata ad h 10,40 m, con braccio verticale
 - 650 Kg di portata ad h 15,90 m, con braccio e Jib verticale
- Tecnologie:**
- Electric Engine Always Allowed.**
Motore elettrico 3 kW con inverter 220 V.
 - Sistema di controllo elettronico.**
Il Sistema di controllo integrato consente alla gru di adeguare automaticamente il limitatore di carico alla situazione determinata dalla posizione di ogni stabilizzatore. Sicurezza totale per l'operatore.
 - No Limits.**
Rotazione infinita senza ingombri grazie al braccio libero da zavorre.
 - Over line Jib.** Jib a +15°, per scavalcare gli ostacoli.
 - Jib Ready to Use.**
Completamente ripiegabile idraulicamente sotto il braccio principale.

