

**MC 305CB -3**



**FULLY BATTERY-POWERED**



**ZERO EMISSIONS**



**LITHIUM-ION BATTERY  
FAST CHARGING SPEED  
CHARGING DURING OPERATION  
WHITE RUBBER TRACKS  
LIGHT WEIGHT & LOW NOISE  
BATTERY MANAGEMENT SYSTEM**

# MC 305CB-3



**Crane Capacity: 2.98t x 2.5m**  
**Max. Lifting Height: 12.52m**  
**Max. Working Radius: 12.16m x 0.26t**  
**Machine Weight: 3925kg**

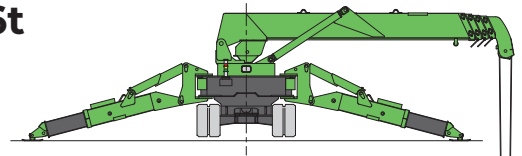

**Working Range Chart (4 Falls)**

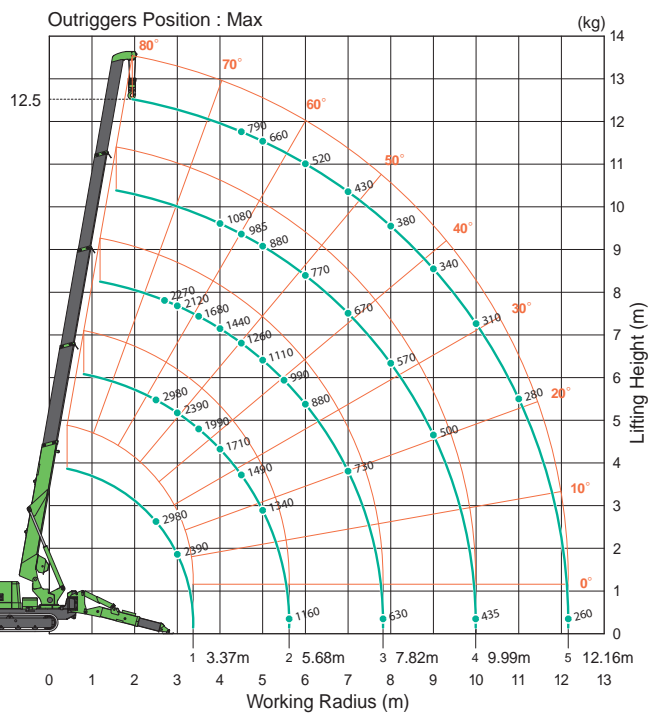

4 Fall 16.09m  
 2 Fall 32.18m  
 Single Fall 64.36m

Black Rubber Tracks (Option)



Searcher Hooks 850kg or 1500kg (Option)



Lithium-Ion Battery

**Rated Total Load Chart (4 Falls)**

Outrigger extended to maximum							
3.695m / 5.945m Boom		8.145m Boom		10.315m Boom		12.485m Boom	
Working radius(m)	Rated total load(kg)	Working radius(m)	Rated total load(kg)	Working radius(m)	Rated total load(kg)	Working radius(m)	Rated total load(kg)
2.5 or less	2980	2.7	2270	4.0	1080	4.5 or less	790
3.0	2390	3.0	2120	4.5	985	5.0	660
3.5	1990	3.5	1680	5.0	880	6.0	520
4.0	1710	4.0	1440	6.0	770	7.0	430
4.5	1490	4.5	1260	7.0	670	8.0	380
5.0	1340	5.0	1110	8.0	570	9.0	340
5.62	1160	5.5	990	9.0	500	10.0	310
		6.0	880	9.99	435	11.0	280
		7.0	730			12.16	260
		7.82	630				

\* The Rated Total Load Chart is based on actual working radius with the bending of boom attributable to load reflected and is shown with the mass of hook (30kg) included.

# MC 305CB -3



## Specifications

Model	MC305CRMB-3		
Crane capacity	2.98t x 2.5m		
Max. working radius	12.16m x 0.26t		
Max. lifting height (on the ground)	12.52m		
Max. lifting height (underground)	-16.09m (4 falls)		
Winch system	Hook speed	9.2m/min (4 layers, 4 falls)	
	Hoist wire rope	IWRC 6 x WS(26) φ 8 x 73m	
Telescoping system	Type	Fully automatic 5-section pentagonal telescopic boom	
	Boom length	3.695 ~ 12.485m	
	Boom telescoping stroke / time	8.79m / 39.6sec	
Boom hoist system	Hoist angle / time	0~80deg / 19.9sec	
Slewing system	swing angle / time	360deg / 1.6rpm	
Outrigger system	Type	Extended Hydraulic cylinder direct acting Setting up Hydraulic cylinder direct acting	
	Max. extended width (outer dims)	(Lateral) 5,170mm x (Front) 4,808mm x (Rear) 4,704mm	
Travel system	Type	Hydraulic motor driven , stepless speed changer	
	Travel speed	0 ~ 1.4km/h	
	Gradability	23deg	
	Crawler ground length x width	1,750mm x 300mm	
	Ground pressure	36.5kpa [0.37kgf/cm <sup>2</sup> ]	
Battery system	Type	Lithium Titanate Battery	
	Capacity	DC55V - 180Ah - 10 kWh	
	Input Voltage / current	Single phase AC200V / 16A, AC100V/15A	
	Charging time	with AC-200V	80% : 3h00min / 100% : 4h30min
		with AC-100V	80% : 8h15min / 100% : 10h30min
	Operating time	Travelling (Hi speed)	up to 3h
		Crane	up to a full working day if charged during operation
	Charging during operation	Available	
Rated Output	Variable 7.5kW AC30V at 2500min <sup>-1</sup>		
Remote control system	Type	Cable remote controller	
	Micro/High speed mode	Available	
	Load display for transmitter	Available	
	Outrigger operation	Available	
Overall length x width x height	4,195mm x 1,280mm x 1,695mm		
Machine weight	3,925kg		
Safety device	Overwind protection, Load indicator, Hydraulic safety valve, Level, Machine body inclination alarm, EMO switch, Travel lock lever, Outrigger interlock device, Moment limiter, Rotary lamp		
Options	Black rubber tracks, Single fall hook, Radio remote control, Searcher hooks (850kg & 1500kg)		



Eco modes

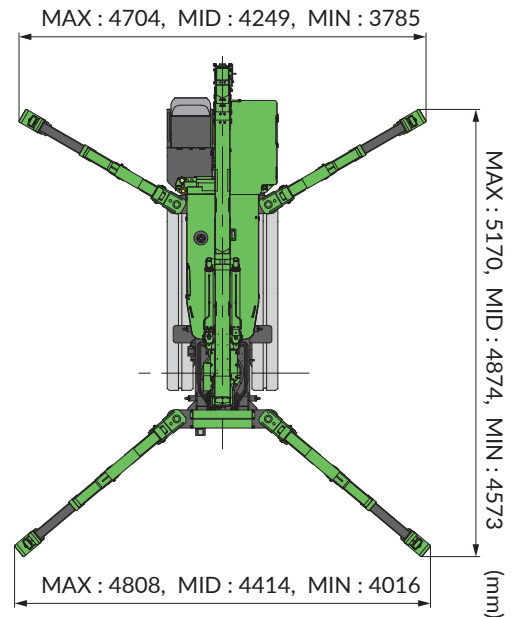

## Dimensions

